

WGC

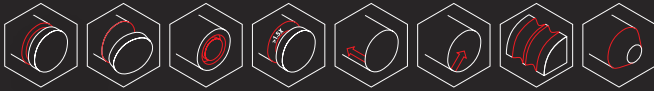

THE MOST VERSATILE TOOL IN THE MARKET FOR GROOVING, PROFILING, AND CUT-OFF OPERATIONS

4 BENEFITS IN 1

VERSATILE

GROOVING, PROFILING,
AND CUT-OFF OPERATIONS

SIMPLE

EASY TO SELECT
AND APPLY

STABLE

TRIPLE-V SEATING FOR
SECURE CLAMPING

PRODUCTIVE

LOW CUTTING FORCES IN
THROUGH COOLANT FOR
BETTER CHIP EVACUATION



Grooving

First choice for external grooving applications in most workpiece materials.

Through coolant capability and efficient coolant delivery for enhanced productivity.

Available in integral and modular style toolholders.

Groove width: 2–10mm.

Cut-Off

Specially engineered chipbreakers for effective parting/cut-off and deep grooving.

Positive geometry for lower forces.

Secure seating offers greatest stability.

Groove width: 1,4–8mm.

Profiling

Full radius chipbreaker for multi-directional turning and generating complex profiles.

Rigid design ensures smooth surface finish.

Groove width: 2–8mm.



New precision ground grooving and cut-off inserts

WIDIA 

widia.com

WGC

Grooving and Cut-Off • WGC

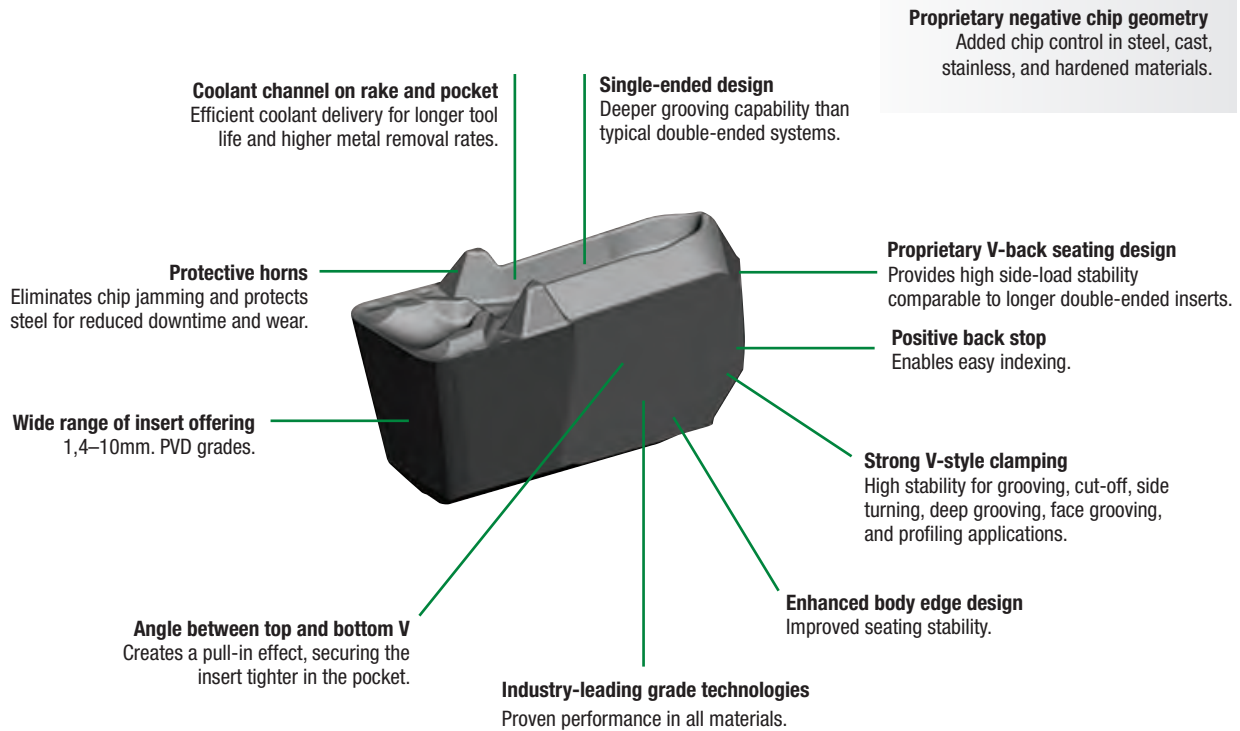

Grooving

Precision Moulded and Ground



P M N S

PT-Positive Rake

Precision Moulded



P M K H

PN-Negative Rake

Precision Moulded and Ground



P M N S

F-Fine

Cut-Off

Precision Moulded



P K

M-Medium



P M

R-Rough

Profiling

Precision Ground



P M N S

PC-Full Radius

NOTE: Use the NOVO™ software to select appropriate toolholder and insert.

WGC Grooving — Competitive Edge

P Steel – P1

Type of cut: Plain

Coolant: External emulsion

19-224222

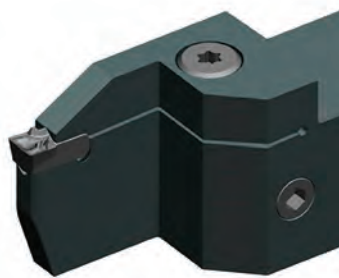









Specifications	Competitor	WIDIA WGC
Workpiece Diameter (mm)	84.5	84.5
Geometry & Grade	-	PT WU25PT
Speed (Vc) (m/min)	100	100
Spindle Speed n (RPM)	377	377
Feed (mm/rev)	0.05	0.05
Grooving Depth	10.2	10.2
Tool Life – No. of Components	5	6

Annual Savings 9%

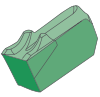

WGC – QUICK FACTS

INSERTS

APPLICATION	TYPES	GROOVE WIDTH	INSERT GEOMETRY	MATERIALS
Grooving		2.0mm–10.13mm .079–0.399"	PT-Positive Rake	
			PN-Negative Rake	
Cut-Off		1.4mm–8.0mm 0.055-0.315"	F-Fine	
			M-Medium	
			R-Rough	
Profiling		2.0mm–8.0mm 0.079-0.315"	PC-Full Radius	

APPLICATIONS

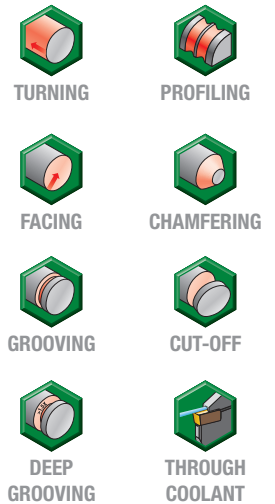

GEOMETRY

4 BENEFITS IN 1

Versatility

Single-sided, versatile grooving and cut-off solution with smooth surface finish

Productivity

Through coolant capability with precise delivery for low cutting forces and better chip evacuation

Stability

In challenging applications due to V-shaped edges

Simplicity

Easy to select and apply

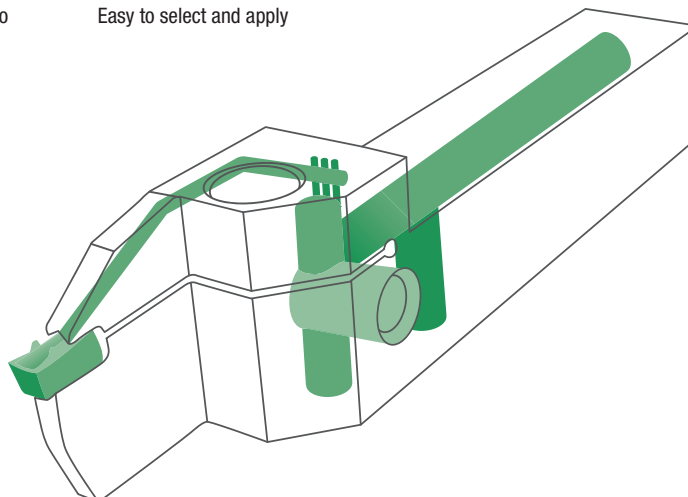

INDUSTRY



How Do Catalogue Numbers Work?

Each character in our catalogue number signifies a specific trait of that product. Use the following key columns and corresponding images to easily identify which attributes apply.

WG0312M03U02PT

W	G	0312	M	03	U	02	PT																																																								
Family Name	Insert Type	Groove Width	Unit	Seat Size	Tolerance	Corner Radius	Chipbreaker/ Edge Condition																																																								
WGC	G = Square R = Full Radius	Metric = 1/100mm Inch = 1/1000"	M = Metric I = Inch		U = Precision Moulded P = Precision Ground		PT = Groove-Turn Universal Positive PN = Groove-Turn Universal Negative																																																								
				<table border="1"> <thead> <tr> <th rowspan="2">seat size (SSC)</th> <th colspan="2">groove width</th> </tr> <tr> <th>mm</th> <th>inch</th> </tr> </thead> <tbody> <tr><td>1B</td><td>1,40</td><td>.055</td></tr> <tr><td>1F</td><td>1,60-1,99</td><td>.063-.078</td></tr> <tr><td>02</td><td>2,00-2,99</td><td>.079-.117</td></tr> <tr><td>03</td><td>3,00-3,99</td><td>.118-.156</td></tr> <tr><td>04</td><td>4,00-4,99</td><td>.157-.196</td></tr> <tr><td>05</td><td>5,00-5,99</td><td>.197-.235</td></tr> <tr><td>06</td><td>6,00-7,99</td><td>.236-.314</td></tr> <tr><td>08</td><td>8,00-8,99</td><td>.315-.353</td></tr> <tr><td>10</td><td>9,00-10,12</td><td>.354-.398</td></tr> </tbody> </table> <p>*.312" = seat size 08</p>	seat size (SSC)	groove width		mm	inch	1B	1,40	.055	1F	1,60-1,99	.063-.078	02	2,00-2,99	.079-.117	03	3,00-3,99	.118-.156	04	4,00-4,99	.157-.196	05	5,00-5,99	.197-.235	06	6,00-7,99	.236-.314	08	8,00-8,99	.315-.353	10	9,00-10,12	.354-.398	<table border="1"> <thead> <tr> <th colspan="2">mm</th> </tr> </thead> <tbody> <tr><td>00</td><td>full radius</td></tr> <tr><td>01</td><td>0,1</td></tr> <tr><td>02</td><td>0,2</td></tr> <tr><td>04</td><td>0,4</td></tr> <tr><td>08</td><td>0,8</td></tr> <tr><td>12</td><td>1,2</td></tr> </tbody> </table> <table border="1"> <thead> <tr> <th colspan="2">inch</th> </tr> </thead> <tbody> <tr><td>00</td><td>full radius</td></tr> <tr><td>05</td><td>.008</td></tr> <tr><td>1</td><td>.016</td></tr> <tr><td>2</td><td>.032</td></tr> <tr><td>3</td><td>.047</td></tr> </tbody> </table>	mm		00	full radius	01	0,1	02	0,2	04	0,4	08	0,8	12	1,2	inch		00	full radius	05	.008	1	.016	2	.032	3	.047
seat size (SSC)	groove width																																																														
	mm	inch																																																													
1B	1,40	.055																																																													
1F	1,60-1,99	.063-.078																																																													
02	2,00-2,99	.079-.117																																																													
03	3,00-3,99	.118-.156																																																													
04	4,00-4,99	.157-.196																																																													
05	5,00-5,99	.197-.235																																																													
06	6,00-7,99	.236-.314																																																													
08	8,00-8,99	.315-.353																																																													
10	9,00-10,12	.354-.398																																																													
mm																																																															
00	full radius																																																														
01	0,1																																																														
02	0,2																																																														
04	0,4																																																														
08	0,8																																																														
12	1,2																																																														
inch																																																															
00	full radius																																																														
05	.008																																																														
1	.016																																																														
2	.032																																																														
3	.047																																																														

WC030M03N00F02

W	C	030	M	03	N	00	F	02																																																															
Family Name	Insert Type	Cutting Edge Width	Unit	Seat Size	Hand of Insert	Approach Angle	Chipbreaker	Corner Radius																																																															
WGC	C = Cut-Off		M = Metric I = Inch		N = Neutral L = Left hand R = Right hand	00 = Neutral 06 = 6°	F = Cut-Off Low Feed M = Cut-Off Fine R = Cut-Off Rough																																																																
		<table border="1"> <thead> <tr> <th></th> <th>mm</th> <th>inch</th> </tr> </thead> <tbody> <tr><td>014</td><td>1,4</td><td>.055</td></tr> <tr><td>020</td><td>2,0</td><td>.079</td></tr> <tr><td>030</td><td>3,0</td><td>.118</td></tr> <tr><td>040</td><td>4,0</td><td>.157</td></tr> <tr><td>050</td><td>5,0</td><td>.197</td></tr> <tr><td>060</td><td>6,0</td><td>.236</td></tr> <tr><td>070</td><td>7,0</td><td>.279</td></tr> <tr><td>080</td><td>8,0</td><td>.315</td></tr> </tbody> </table>		mm	inch	014	1,4	.055	020	2,0	.079	030	3,0	.118	040	4,0	.157	050	5,0	.197	060	6,0	.236	070	7,0	.279	080	8,0	.315		<table border="1"> <thead> <tr> <th></th> <th>mm</th> <th>inch</th> </tr> </thead> <tbody> <tr><td>1B</td><td>1,4</td><td>.055</td></tr> <tr><td>1F</td><td>2,0</td><td>.079</td></tr> <tr><td>02</td><td>3,0</td><td>.118</td></tr> <tr><td>03</td><td>4,0</td><td>.157</td></tr> <tr><td>04</td><td>5,0</td><td>.197</td></tr> <tr><td>05</td><td>6,0</td><td>.236</td></tr> <tr><td>06</td><td>7,0</td><td>.279</td></tr> <tr><td>08</td><td>8,0</td><td>.315</td></tr> </tbody> </table>		mm	inch	1B	1,4	.055	1F	2,0	.079	02	3,0	.118	03	4,0	.157	04	5,0	.197	05	6,0	.236	06	7,0	.279	08	8,0	.315	<table border="1"> <thead> <tr> <th></th> <th>mm</th> <th>inch</th> </tr> </thead> <tbody> <tr><td>01</td><td>0,1</td><td>.004</td></tr> <tr><td>02</td><td>0,2</td><td>.008</td></tr> <tr><td>04</td><td>0,4</td><td>.016</td></tr> </tbody> </table>		mm	inch	01	0,1	.004	02	0,2	.008	04	0,4	.016
	mm	inch																																																																					
014	1,4	.055																																																																					
020	2,0	.079																																																																					
030	3,0	.118																																																																					
040	4,0	.157																																																																					
050	5,0	.197																																																																					
060	6,0	.236																																																																					
070	7,0	.279																																																																					
080	8,0	.315																																																																					
	mm	inch																																																																					
1B	1,4	.055																																																																					
1F	2,0	.079																																																																					
02	3,0	.118																																																																					
03	4,0	.157																																																																					
04	5,0	.197																																																																					
05	6,0	.236																																																																					
06	7,0	.279																																																																					
08	8,0	.315																																																																					
	mm	inch																																																																					
01	0,1	.004																																																																					
02	0,2	.008																																																																					
04	0,4	.016																																																																					

Grooving and Cut-Off • WGC

Integral Straight • Metric

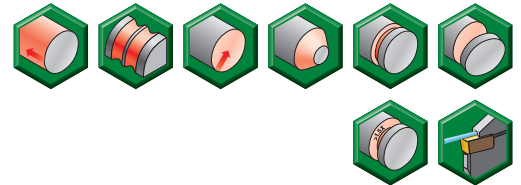
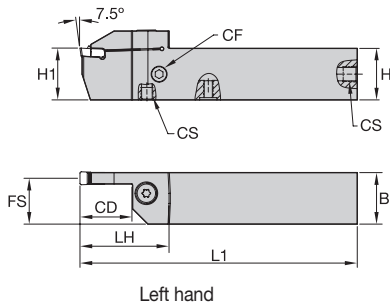

order number	catalogue number	SSC	CD	H1	H	B	H2	L1	FS	LH	CF	CS
right hand												
6461946	WGCSMR2020K0216	2	16	20	20	20	27	125	19	31	—	—
6461948	WGCSMR2525M0216	2	16	25	25	25	32	150	24	31	—	—
6461950	WGCSMR2020K0222	2	22	20	20	20	29	125	19	38	—	—
6461952	WGCSMR2525M0226	2	26	25	25	25	34	150	24	42	—	—
6462003	WGCSMR2020K0316C	3	16	20	20	20	29	125	19	37	M8X1	M8X1
6462004	WGCSMR2525M0316C	3	16	25	25	25	34	150	24	37	G 1/8	G 1/8
6462005	WGCSMR2020K0322C	3	22	20	20	20	30	125	19	43	M8X1	M8X1
6462006	WGCSMR2525M0326C	3	26	25	25	25	35	150	24	47	G 1/8	G 1/8
6462007	WGCSMR2020K0416C	4	16	20	20	20	29	125	18	37	M8X1	M8X1
6462008	WGCSMR2525M0416C	4	16	25	25	25	34	150	23	37	G 1/8	G 1/8
6462009	WGCSMR2020K0422C	4	22	20	20	20	30	125	18	43	M8X1	M8X1
6462010	WGCSMR2525M0426C	4	26	25	25	25	35	150	23	47	G 1/8	G 1/8
6462061	WGCSMR3232P0426C	4	26	32	32	32	42	170	30	47	G 1/8	G 1/8
6462062	WGCSMR3232P0432C	4	32	32	32	32	42	170	30	53	G1/8-28	G1/8-28
6462063	WGCSMR2525M0516C	5	16	25	25	25	34	150	23	37	G 1/8	G 1/8
6462064	WGCSMR2525M0526C	5	26	25	25	25	35	150	23	47	G1/8-28	G1/8-28
6462065	WGCSMR3232P0526C	5	26	32	32	32	42	170	30	47	G 1/8	G 1/8
6462066	WGCSMR3232P0532C	5	32	32	32	32	42	170	30	53	G 1/8	G 1/8
6462067	WGCSMR2525M0616C	6	16	25	25	25	34	150	22	37	G 1/8	G 1/8
6462068	WGCSMR2525M0626C	6	26	25	25	25	35	150	22	47	G1/8-28	G1/8-28
6462069	WGCSMR3232P0626C	6	26	32	32	32	42	170	29	47	G 1/8	G 1/8
6462070	WGCSMR3232P0632C	6	32	32	32	32	44	170	29	55	G 1/8	G 1/8
6462071	WGCSMR4040R0640C	6	40	40	40	40	52	200	37	63	G 1/8	G 1/8
6462072	WGCSMR2525M0826C	8	26	25	25	25	36	150	21	49	G 1/8	G 1/8
6462073	WGCSMR3232P0826C	8	26	32	32	32	43	170	28	49	G 1/8	G 1/8
6462074	WGCSMR3232P0832C	8	32	32	32	32	44	170	28	55	G 1/8	G 1/8
6462075	WGCSMR4040R0840C	8	40	40	40	40	52	200	36	63	G1/8-28	G1/8-28
6462076	WGCSMR3232P1032C	10	32	32	32	32	44	170	28	55	G 1/8	G 1/8
6462077	WGCSMR4040R1040C	10	40	40	40	40	52	200	36	63	G 1/8	G 1/8
left hand												
6461954	WGCSML2020K0216	2	16	20	20	20	27	125	19	31	—	—
6461956	WGCSML2525M0216	2	16	25	25	25	32	150	24	31	—	—
6461958	WGCSML2020K0222	2	22	20	20	20	29	125	19	38	—	—
6461960	WGCSML2525M0226	2	26	25	25	25	34	150	24	42	—	—
6462078	WGCSML2020K0316C	3	16	20	20	20	29	125	19	37	M8X1	M8X1
6462079	WGCSML2525M0316C	3	16	25	25	25	34	150	24	37	G 1/8	G 1/8
6462080	WGCSML2020K0322C	3	22	20	20	20	30	125	19	43	M8X1	M8X1
6462091	WGCSML2525M0326C	3	26	25	25	25	35	150	24	47	G 1/8	G 1/8
6462092	WGCSML2020K0416C	4	16	20	20	20	29	125	18	37	M8X1	M8X1



Integral Straight • Metric

(continued)

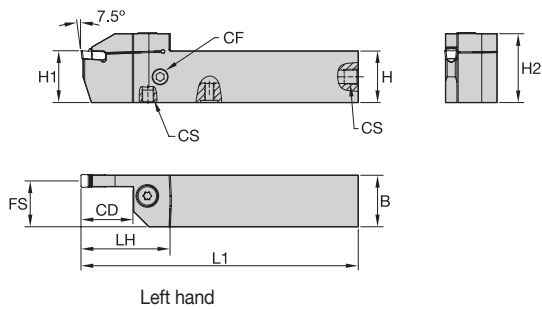

order number	catalogue number	SSC	CD	H1	H	B	H2	L1	FS	LH	CF	CS
6462093	WGCSML2525M0416C	4	16	25	25	25	34	150	23	37	G 1/8	G 1/8
6462094	WGCSML2020K0422C	4	22	20	20	20	30	125	18	43	M8X1	M8X1
6462095	WGCSML2525M0426C	4	26	25	25	25	35	150	23	47	G 1/8	G 1/8
6462096	WGCSML3232P0426C	4	26	32	32	32	42	170	30	47	G1/8-28	G1/8-28
6462097	WGCSML3232P0432C	4	32	32	32	32	42	170	30	53	G 1/8	G 1/8
6462098	WGCSML2525M0516C	5	16	25	25	25	34	150	23	37	G1/8-28	G1/8-28
6462099	WGCSML2525M0526C	5	26	25	25	25	35	150	23	47	G 1/8	G 1/8
6462100	WGCSML3232P0526C	5	26	32	32	32	42	170	30	47	G 1/8	G 1/8
6462101	WGCSML3232P0532C	5	32	32	32	32	42	170	30	53	G 1/8	G 1/8
6462102	WGCSML2525M0616C	6	16	25	25	25	34	150	22	37	G 1/8	G 1/8
6462103	WGCSML2525M0626C	6	26	25	25	25	35	150	22	47	G 1/8	G 1/8
6462104	WGCSML3232P0626C	6	26	32	32	32	42	170	29	47	G 1/8	G 1/8
6462105	WGCSML3232P0632C	6	32	32	32	32	44	170	29	55	G 1/8	G 1/8
6462106	WGCSML4040R0640C	6	40	40	40	40	52	200	37	63	G1/8-28	G1/8-28
6462107	WGCSML2525M0826C	8	26	25	25	25	36	150	21	49	G1/8-28	G1/8-28
6462108	WGCSML3232P0826C	8	26	32	32	32	43	170	28	49	G 1/8	G 1/8
6462109	WGCSML3232P0832C	8	32	32	32	32	44	170	28	55	G1/8-28	G1/8-28
6462110	WGCSML4040R0840C	8	40	40	40	40	52	200	36	63	G 1/8	G 1/8
6462111	WGCSML3232P1032C	10	32	32	32	32	44	170	28	55	G 1/8	G 1/8
6462112	WGCSML4040R1040C	10	40	40	40	40	52	200	36	63	G 1/8	G 1/8

NOTE: SSC = Pocket Seat Reference. To correspond with the SSC on the insert.

WGC Modular Toolholders

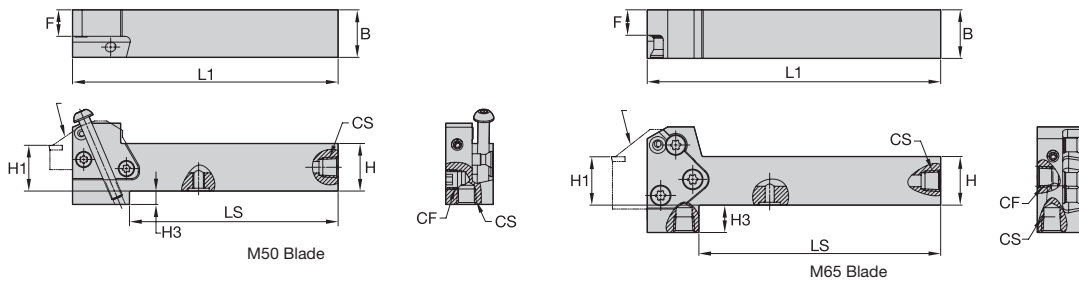
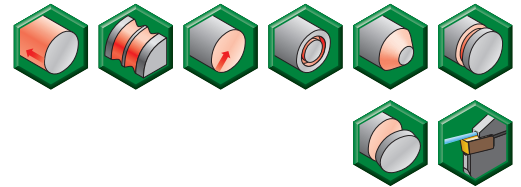

order number	catalogue number	B	H	H1	L1	F	CS	CF	LS	H3	blade size
right hand											
6499222	WGCMSR2525M50C	25	25	25	138,75	13,84	G 1/8-28	G 1/8-28	109,00	7,00	50
6499223	WGCMSR2525M65C	25	25	25	150,00	13,00	G 1/8-28	G 1/8-28	122,00	—	65
6499224	WGCMSR3232P50C	32	32	32	158,75	20,08	G 1/8-28	G 1/8-28	133,62	—	50
6499225	WGCMSR3232P65C	32	32	32	170,00	20,00	G 1/8-28	G 1/8-28	142,00	21,75	65
left hand											
6499226	WGCMSL2525M50C	25	25	25	138,75	13,84	G 1/8-28	G 1/8-28	109,00	7,00	50
6499227	WGCMSL2525M65C	25	25	25	150,00	13,00	G 1/8-28	G 1/8-28	122,00	29,00	65
6499228	WGCMSL3232P50C	32	32	32	158,75	20,08	G 1/8-28	G 1/8-28	133,62	—	50
6499229	WGCMSL3232P65C	32	32	32	170,00	20,00	G 1/8-28	G 1/8-28	142,00	21,75	65

NOTE: WGCMS...: Right-hand holder uses right-hand blades.
 WGCME...: Right-hand holder uses left-hand blades.
 M50 blade and clamp screw torque equals 71–88 in. lbs. (8–10 Nm).
 M65 blade and clamp screw torque equals 159–177 in. lbs. (18–20 Nm).

WGC Modular Toolholders

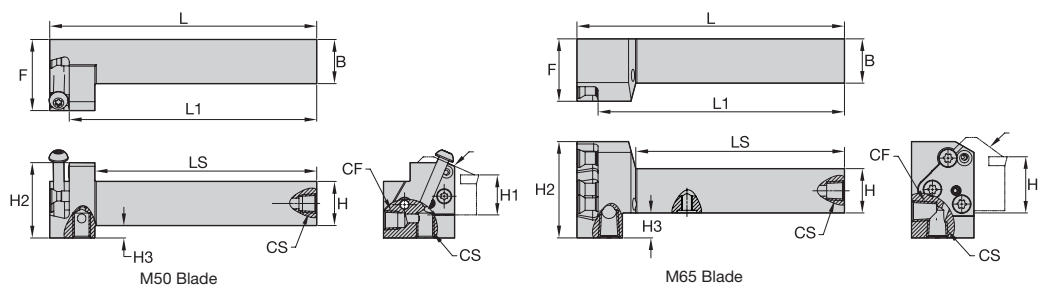
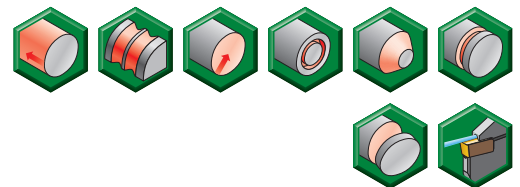

order number	catalogue number	B	H	H1	L	L1	LS	F	CS	CF	H2	H3	blade size
right hand													
6498953	WGCMER2525M65C	25	25	25	150,00	138,15	117,00	35,00	G 1/8-28	G 1/8-28	54,00	14,00	65
6498954	WGCMER2525M50C	25	25	25	150,25	139,25	125,25	40,00	G 1/8-28	G 1/8-28	42,41	7,00	50
6498955	WGCMER3232P65C	32	32	32	170,00	158,15	137,00	35,00	G 1/8-28	G 1/8-28	54,00	7,00	65
6498956	WGCMER3232P50C	32	32	32	170,25	159,25	145,25	40,00	G 1/8-28	G 1/8-28	42,41	—	50
left hand													
6498957	WGCME2525M65C	25	25	25	150,00	138,15	117,00	35,00	G 1/8-28	G 1/8-28	54,00	14,00	65
6498958	WGCME2525M50C	25	25	25	150,25	139,25	125,25	40,00	G 1/8-28	G 1/8-28	42,41	7,00	50
6498959	WGCME3232P65C	32	32	32	170,00	158,15	137,00	35,00	G 1/8-28	G 1/8-28	54,00	7,00	65
6498960	WGCME3232P50C	32	32	32	170,25	159,25	145,25	40,00	G 1/8-28	G 1/8-28	42,41	—	50

NOTE: WGCMS.: Right-hand holder uses right-hand blades.
 WGCME.: Right-hand holder uses left-hand blades.
 M50 blade and clamp screw torque equals 71–88 in. lbs. (8–10 Nm).
 M65 blade and clamp screw torque equals 159–177 in. lbs. (18–20 Nm).

Grooving and Cut-Off • WGC

WGC Modular Blades

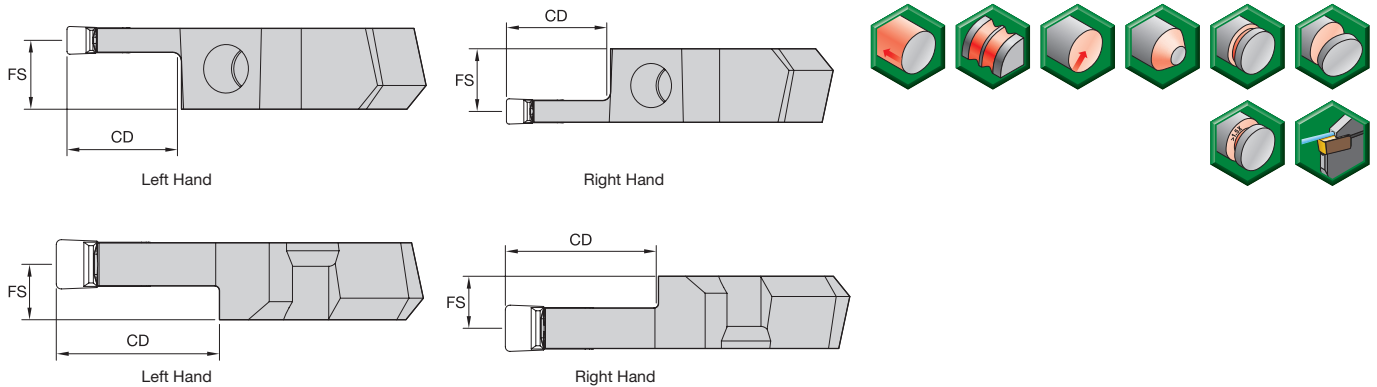

order number	catalogue number	SSC	CD	FS	blade size
right hand					
6498457	WGCM50R1F12M	1F	12,0	11,00	50
6498458	WGCM50R0212M	2	12,0	10,88	50
6498459	WGCM50R0216M	2	16,0	10,88	50
6498460	WGCM50R0312MC	3	12,0	10,43	50
6498861	WGCM50R0322MC	3	22,0	10,43	50
6498862	WGCM50R0412MC	4	12,0	9,93	50
6498863	WGCM50R0422MC	4	22,0	9,93	50
6498864	WGCM50R0432MC	4	32,0	9,93	50
6498865	WGCM50R0512MC	5	12,0	9,43	50
6498866	WGCM50R0516MC	5	16,0	9,43	50
6498867	WGCM50R0526MC	5	26,0	9,43	50
6498868	WGCM50R0532MC	5	32,0	9,43	50
6498869	WGCM65R0616MC	6	16,0	9,88	65
6498870	WGCM65R0626MC	6	26,0	9,88	65
6498881	WGCM65R0632MC	6	32,0	9,88	65
6498882	WGCM65R0816MC	8	16,0	9,00	65
6498883	WGCM65R0826MC	8	26,0	9,00	65
left hand					
6498884	WGCM50L1F12M	1F	12,0	11,00	50
6498885	WGCM50L0212M	2	12,0	10,88	50
6498886	WGCM50L0216M	2	16,0	10,88	50
6498887	WGCM50L0312MC	3	12,0	10,43	50
6498888	WGCM50L0322MC	3	22,0	10,43	50
6498889	WGCM50L0412MC	4	12,0	9,93	50
6498890	WGCM50L0422MC	4	22,0	9,93	50
6498891	WGCM50L0432MC	4	32,0	9,93	50
6498892	WGCM50L0512MC	5	12,0	9,43	50
6498893	WGCM50L0516MC	5	16,0	9,43	50
6498894	WGCM50L0526MC	5	26,0	9,43	50
6498895	WGCM50L0532MC	5	32,0	9,43	50
6498896	WGCM65L0616MC	6	16,0	9,88	65
6498897	WGCM65L0626MC	6	26,0	9,88	65
6498898	WGCM65L0632MC	6	32,0	9,88	65
6498899	WGCM65L0816MC	8	16,0	9,00	65
6498900	WGCM65L0826MC	8	26,0	9,00	65

NOTE: SSC = Pocket Seat Reference. To correspond with the SSC on the insert.
Through the pocket coolant available in seat sizes 3 and higher.

Blade Holders • Metric

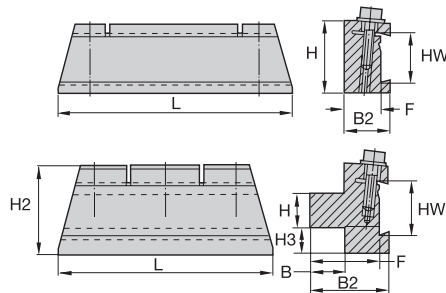

order number	catalogue number	HW	H	B	F	H2	B2	H3	L
2007826	12251222000	26	20,0	18,0	33,0	40	38	8	100
2021635	12251222500	32	25,0	20,0	35,0	50	40	10	125
2008159	12251233200	53	32,0	25,0	50,0	82	57	30	160
2021723	12251234000	53	40,0	40,0	58,0	82	65	22	160

Double-Ended Cut-Off Blade

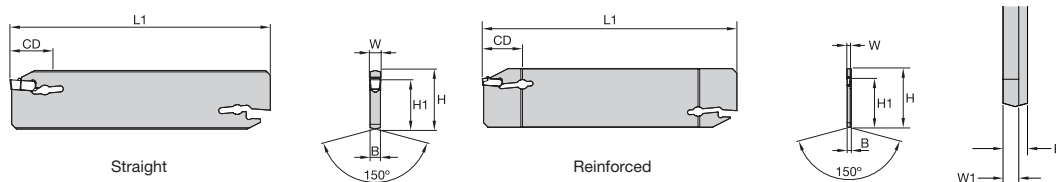

order number	catalogue number	SSC	H	W	W1	H1	L1	B	CD
neutral hand									
6498987	WGCBSN19G1B14	1B	19	1,4	1,15	15,5	90	1,80	14
6498988	WGCBSN26J1B15	1B	26	1,4	1,15	21,5	110	1,80	15
6498989	WGCBSN19G1F16	1F	19	1,6	1,30	15,5	90	1,80	16
6498990	WGCBSN26J1F17	1F	26	1,6	1,30	21,5	110	1,80	17
6499211	WGCBSN19G0220	2	19	2,0	—	15,5	90	1,65	20
6499212	WGCBSN26J0230	2	26	2,0	—	21,5	110	1,65	30
6499213	WGCBSN32M0250	2	32	2,0	—	25,1	150	1,65	50
6499214	WGCBSN26J0340	3	26	3,0	—	21,5	110	2,40	40
6499215	WGCBSN32M0350	3	32	3,0	—	25,1	150	2,40	50
6499216	WGCBSN26J0440	4	26	4,0	—	21,5	110	3,40	40
6499217	WGCBSN32M0450	4	32	4,0	—	25,1	150	3,40	50
6499218	WGCBSN32M0560	5	32	5,0	—	25,1	150	4,40	60
6499219	WGCBSN32M0660	6	32	6,0	—	25,1	150	5,40	60
6499220	WGCBSN32M0860	8	32	8,0	—	25,1	150	7,00	60
6499221	WGCBSN52X08120	8	53	8,0	—	45,3	260	7,00	120

NOTE: SSC = Pocket Seat Reference. To correspond with the SSC on the insert.

Grades and Grade Descriptions

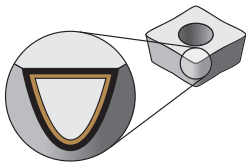

Coatings provide high-speed capability and are engineered for finishing to heavy roughing.

P	Steel
M	Stainless Steel
K	Cast Iron
N	Non-Ferrous
S	High-Temp Alloys
H	Hardened Materials

wear resistance ← → toughness

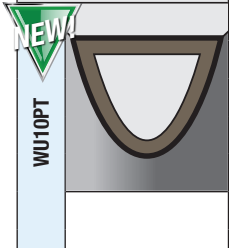
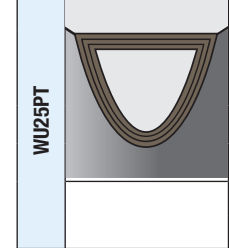
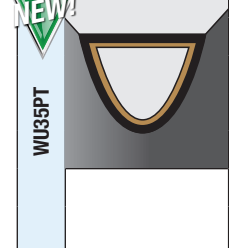
Coating	Grade Description		05	10	15	20	25	30	35	40	45		
 WU10PT	<p>Composition: An advanced multilayer PVD coating over a very deformation-resistant unalloyed carbide substrate. The new and improved coating improves edge stability with wide range speed and feed capabilities.</p> <p>Application: The WU10PT™ grade is ideal for finishing to general machining of most workpiece materials at a wide range of speed and feed capabilities. Excellent for machining most steels, stainless steels, cast irons, non-ferrous materials, and super alloys with improved edge toughness and higher cutting speed/feed capability.</p>	P											
		M											
		K											
		N											
		S											
		H											
 WU25PT	<p>Composition: An advanced PVD-TiAlN-coated grade with a tough, ultra-fine grain, unalloyed substrate.</p> <p>Application: For general-purpose machining of most steels, stainless steels, high-temperature alloys, titanium, irons, and non-ferrous materials. Speeds may vary from low to medium and will handle interruptions and high feed rates.</p>	P											
		M											
		K											
		N											
		S											
		H											
 WU35PT	<p>Composition: A multilayer PVD coated carbide grade with an advanced AlTiN-TiN coating over a super-tough substrate.</p> <p>Application: WU35PT is an excellent grade for machining stainless steels, all types of steels, super alloys in turning, and cut-off applications. The substrate provides improved toughness while the coating layers offer excellent abrasion resistance and dependability at a wide range of speeds and feeds. Improved edge toughness provides security in interrupted cuts.</p>	P											
		M											
		K											
		N											
		S											
		H											

Cut-Off Inserts • F Precision Moulded • Metric

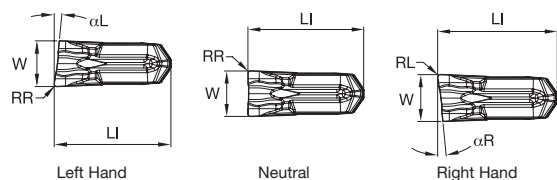

- first choice
- alternate choice

P	●
M	●
K	○
N	○
S	●
H	

catalogue number	SSC	W	W tol ±	LI	αR	αL	RR	RL	WU25PT
WC014M1BL06F01	1B	1,40	0,050	9,00	—	6	0,15	—	6470544
WC014M1BN00F01	1B	1,40	0,050	9,00	—	—	0,15	0,15	6470545
WC014M1BR06F01	1B	1,40	0,050	9,02	6	—	—	0,15	6470546
WC020M02L06F02	2	2,00	0,050	9,00	—	6	0,20	—	6470547
WC020M02N00F02	2	2,00	0,050	9,00	—	—	0,20	0,20	6470548
WC020M02R06F02	2	2,00	0,050	9,00	6	—	—	0,20	6470549
WC030M03L06F02	3	3,00	0,075	9,60	—	6	0,20	—	6470550
WC030M03N00F02	3	3,00	0,075	9,63	—	—	0,20	0,20	6470561
WC030M03R06F02	3	3,00	0,075	9,60	6	—	—	—	6470562
WC040M04L06F02	4	4,00	0,075	10,19	—	6	0,20	—	6470563
WC040M04N00F02	4	4,00	0,075	10,19	—	—	0,20	0,20	6470564
WC040M04R06F02	4	4,00	0,075	10,19	6	—	—	0,20	6470565
WC050M05N00F03	5	5,00	0,075	12,24	—	—	0,30	0,30	6470566

NOTE: SSC = Pocket Seat Reference. To correspond with the SSC on the toolholder.

Grooving and Cut-Off • WGC

Cut-Off Inserts • M Precision Moulded • Metric

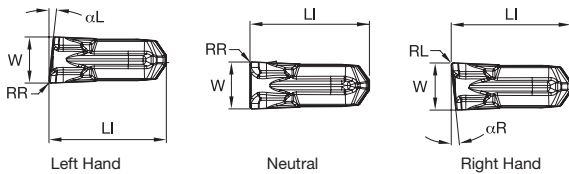

- first choice
- alternate choice

P	●
M	●
K	○
N	○
S	●
H	

catalogue number	SSC	W	W tol ±	LI	αR	αL	RR	RL	WU25PT
WC014M1BL06M02	1B	1,40	0,050	9,02	—	6	—	0,20	6461828
WC014M1BN00M01	1B	1,40	0,050	9,01	—	—	0,15	0,15	6461829
WC014M1BR06M02	1B	1,40	0,050	9,02	6	—	—	0,20	6461830
WC020M02L06M02	2	2,00	0,050	8,97	—	6	—	0,20	6461861
WC020M02N00M02	2	2,00	0,050	8,98	—	—	0,20	0,20	6461862
WC020M02R06M02	2	2,00	0,050	9,00	6	—	—	0,20	6461863
WC030M03L06M02	3	3,00	0,075	9,61	—	6	—	0,20	6461864
WC030M03N00M02	3	3,00	0,075	9,60	—	—	0,20	0,20	6461865
WC030M03R06M02	3	3,00	0,075	9,61	6	—	—	0,20	6461866
WC040M04L06M02	4	4,00	0,075	10,19	—	6	0,20	—	6461867
WC040M04N00M02	4	4,00	0,075	10,20	—	—	0,20	0,20	6461868
WC040M04R06M02	4	4,00	0,050	10,20	6	—	—	0,20	6461869
WC050M05N00M03	5	5,00	0,075	12,25	—	—	0,30	0,30	6461870
WC060M06N00M03	6	6,00	0,075	14,59	—	—	0,30	0,30	6461881
WC080M08N00M04	8	8,00	0,075	17,46	—	—	0,40	0,40	6461882

NOTE: SSC = Pocket Seat Reference. To correspond with the SSC on the toolholder.

Cut-Off Inserts • R Precision Moulded • Metric

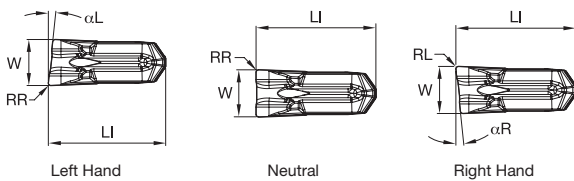

- first choice
- alternate choice

P	●
M	●
K	○
N	○
S	●
H	

catalogue number	SSC	W	W tol ±	LI	αR	αL	RR	RL	WU25PT
WC020M02L06R02	2	2,00	0,050	8,97	—	6	0,20	—	6470426
WC020M02N00R02	2	2,00	0,050	8,98	—	—	0,20	0,20	6470427
WC020M02R06R02	2	2,00	0,050	8,97	6	—	—	0,20	6470428
WC030M03L06R02	3	3,00	0,075	9,61	—	6	0,20	—	6470429
WC030M03N00R02	3	3,00	0,075	9,60	—	—	0,20	0,20	6470430
WC030M03R06R02	3	3,00	0,075	9,61	6	—	—	0,20	6470461
WC040M04N00R02	4	4,00	0,075	10,20	—	—	0,20	0,20	6470462
WC050M05N00R03	5	5,00	0,075	12,25	—	—	0,30	0,30	6470463
WC060M06N00R03	6	6,00	0,075	14,59	—	—	0,30	0,30	6470464
WC080M08N00R04	8	8,00	0,075	17,46	—	—	0,40	0,40	6470465

NOTE: SSC = Pocket Seat Reference. To correspond with the SSC on the toolholder.

Grooving Inserts • PT Precision Moulded • Metric

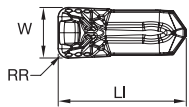

- first choice
- alternate choice

P	●
M	●
K	○
N	○
S	●
H	

catalogue number	SSC	W	W tol ±	RR	LI	WU25PT
WG0212M02U02PT	2	2,13	0,050	0,20	8,97	6461734
WG0251M02U02PT	2	2,51	0,050	0,20	8,97	6461735
WG0312M03U02PT	3	3,13	0,075	0,20	9,60	6461736
WG0312M03U04PT	3	3,13	0,075	0,40	9,60	6461737
WG0412M04U04PT	4	4,13	0,075	0,40	10,19	6461738
WG0412M04U08PT	4	4,13	0,075	0,80	10,19	6461739
WG0512M05U04PT	5	5,13	0,075	0,40	12,25	6461740
WG0512M05U08PT	5	5,13	0,075	0,80	12,25	6461821
WG0612M06U04PT	6	6,13	0,075	0,40	14,59	6461822
WG0612M06U08PT	6	6,13	0,075	0,80	14,59	6461823
WG0712M06U08PT	6	7,13	0,075	0,80	14,59	6461824
WG0812M08U08PT	8	8,13	0,075	0,80	17,45	6461825
WG0812M08U12PT	8	8,13	0,075	1,20	17,45	6461826
WG1012M10U12PT	10	10,13	0,075	1,20	20,75	6461827

NOTE: SSC = Pocket Seat Reference. To correspond with the SSC on the toolholder.

Grooving Inserts • PT Precision Ground • Metric

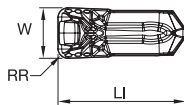

- first choice
- alternate choice

P	●
M	●
K	○
N	○
S	●
H	

catalogue number	SSC	W	W tol ±	RR	LI	WU25PT
WG0200M02P02PT	2	2,00	0,025	0,20	8,92	6741598
WG0300M03P02PT	3	3,00	0,025	0,20	9,55	6741599
WG0300M03P04PT	3	3,00	0,025	0,40	9,55	6741600
WG0400M04P04PT	4	4,00	0,025	0,40	10,15	6741611
WG0400M04P08PT	4	4,00	0,025	0,80	10,15	6741612
WG0500M05P04PT	5	5,00	0,025	0,40	12,18	6741613
WG0500M05P08PT	5	5,00	0,025	0,08	12,20	6741614
WG0600M06P04PT	6	6,00	0,025	0,40	14,53	6741615
WG0600M06P08PT	6	6,00	0,025	0,80	14,54	6741616

NOTE: SSC = Pocket Seat Reference. To correspond with the SSC on the toolholder.

Grooving and Cut-Off • WGC

Grooving Inserts • PN Precision Moulded • Metric

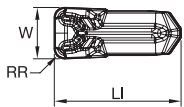

- first choice
- alternate choice

P	●
M	●
K	○
N	○
S	●
H	

catalogue number	SSC	W	W tol ±	RR	LI	WU25PT
WG0212M02U02PN	2	2,13	0,050	0,20	8,97	6470850
WG0251M02U02PN	2	2,51	0,050	0,20	8,97	6471041
WG0312M03U02PN	3	3,13	0,075	0,20	9,60	6471042
WG0312M03U04PN	3	3,13	0,075	0,40	9,60	6471043
WG0412M04U04PN	4	4,13	0,075	0,40	10,20	6471044
WG0412M04U08PN	4	4,13	0,075	0,80	10,20	6471045
WG0512M05U04PN	5	5,13	0,075	0,40	12,24	6471046
WG0512M05U08PN	5	5,13	0,075	0,80	12,24	6471047
WG0612M06U04PN	6	6,13	0,075	0,40	14,59	6471048
WG0612M06U08PN	6	6,13	0,075	0,80	14,59	6471049
WG0812M08U08PN	8	8,13	0,075	0,80	17,46	6471050
WG0812M08U12PN	8	8,13	0,075	1,20	17,46	6471062
WG1012M10U12PN	10	10,13	0,075	1,20	20,75	6471064

NOTE: SSC = Pocket Seat Reference. To correspond with the SSC on the toolholder.

Grooving Inserts • PC Full Radius Precision Ground • Metric

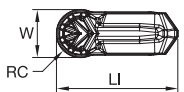

- first choice
- alternate choice

P	●
M	●
K	○
N	○
S	●
H	

catalogue number	SSC	W	W tol ±	RC	LI	WU25PT
WR0200M02P00PC	2	2,00	0,025	1,00	8,91	6470467
WR0300M03P00PC	3	3,00	0,025	1,50	9,54	6470468
WR0400M04P00PC	4	4,00	0,025	2,00	10,13	6470469
WR0500M05P00PC	5	5,00	0,025	2,50	12,18	6470470
WR0600M06P00PC	6	6,00	0,025	3,00	14,52	6470481
WR0800M08P00PC	8	8,00	0,025	4,00	17,41	6470482

NOTE: SSC = Pocket Seat Reference. To correspond with the SSC on the toolholder.

Plunge feed rates

- first choice
- alternate choice

P Steel	K Cast Iron	S High-Temp Alloys
M Stainless Steel	N Non-Ferrous	H Hardened Materials

Chip Control	Description	Insert Geometry	Seat Size (SSC)	Corner Radius mm	Starting Conditions mm	Plunge Feed Rates mm/rev						
						0,05	0,10	0,15	0,20	0,25	0,30	0,35
-PT 	Positive rake angle for lower cutting forces. 		1F	0,2	0,06	0,05	0,10	0,15	0,20	0,25	0,30	0,35
			2	0,2	0,08	0,05	0,10	0,15	0,20	0,25	0,30	0,35
			3	0,2	0,09	0,05	0,10	0,15	0,20	0,25	0,30	0,35
			4	0,4	0,11	0,05	0,10	0,15	0,20	0,25	0,30	0,35
			4	0,4	0,12	0,05	0,10	0,15	0,20	0,25	0,30	0,35
			5	0,4	0,15	0,05	0,10	0,15	0,20	0,25	0,30	0,35
			6	0,8	0,16	0,05	0,10	0,15	0,20	0,25	0,30	0,35
			6	0,4	0,15	0,05	0,10	0,15	0,20	0,25	0,30	0,35
			8	0,8	0,20	0,05	0,10	0,15	0,20	0,25	0,30	0,35
			8	1,2	0,22	0,05	0,10	0,15	0,20	0,25	0,30	0,35
-PN 	Stable negative cutting edge allowing for more aggressive applications. 		1F	0,2	0,06	0,05	0,10	0,15	0,20	0,25	0,30	0,35
			2	0,2	0,08	0,05	0,10	0,15	0,20	0,25	0,30	0,35
			3	0,2	0,09	0,05	0,10	0,15	0,20	0,25	0,30	0,35
			4	0,4	0,11	0,05	0,10	0,15	0,20	0,25	0,30	0,35
			4	0,4	0,12	0,05	0,10	0,15	0,20	0,25	0,30	0,35
			5	0,4	0,15	0,05	0,10	0,15	0,20	0,25	0,30	0,35
			6	0,8	0,16	0,05	0,10	0,15	0,20	0,25	0,30	0,35
			6	0,4	0,15	0,05	0,10	0,15	0,20	0,25	0,30	0,35
			8	0,8	0,18	0,05	0,10	0,15	0,20	0,25	0,30	0,35
			8	1,2	0,20	0,05	0,10	0,15	0,20	0,25	0,30	0,35

Cut-Off Feed Rates

Geometry	Description	Insert Geometry	Seat Size (SSC)	Starting Conditions mm	Cut-Off Feed Rates mm/rev							
					0,05	0,10	0,15	0,20	0,25	0,30	0,35	0,40
-F 	Positive geometry for reduced cutting forces. 		1B	0,06	0,05	0,10	0,15	0,20	0,25	0,30	0,35	0,40
			2	0,07	0,05	0,10	0,15	0,20	0,25	0,30	0,35	0,40
			3	0,09	0,05	0,10	0,15	0,20	0,25	0,30	0,35	0,40
			4	0,11	0,05	0,10	0,15	0,20	0,25	0,30	0,35	0,40
			5	0,13	0,05	0,10	0,15	0,20	0,25	0,30	0,35	0,40
-M 	Stable cutting edge for aggressive feed rates. Primarily in cast iron. 		1B	0,06	0,05	0,10	0,15	0,20	0,25	0,30	0,35	0,40
			2	0,07	0,05	0,10	0,15	0,20	0,25	0,30	0,35	0,40
			3	0,09	0,05	0,10	0,15	0,20	0,25	0,30	0,35	0,40
			4	0,11	0,05	0,10	0,15	0,20	0,25	0,30	0,35	0,40
			5	0,14	0,05	0,10	0,15	0,20	0,25	0,30	0,35	0,40
			6	0,16	0,05	0,10	0,15	0,20	0,25	0,30	0,35	0,40
-R 	Most stable cutting edge for steel. 		2	0,10	0,05	0,10	0,15	0,20	0,25	0,30	0,35	0,40
			3	0,14	0,05	0,10	0,15	0,20	0,25	0,30	0,35	0,40
			4	0,16	0,05	0,10	0,15	0,20	0,25	0,30	0,35	0,40
			5	0,19	0,05	0,10	0,15	0,20	0,25	0,30	0,35	0,40
			6	0,21	0,05	0,10	0,15	0,20	0,25	0,30	0,35	0,40
			8	0,23	0,05	0,10	0,15	0,20	0,25	0,30	0,35	0,40

NOTE: For cut-off inserts with a lead angle, maximum feed rate should be reduced by up to 40%.

Maximum Feed Rate Values

Data above is for P and K material groups. Maximum feed rates should be adjusted by multiplying max feed rate values by following factors for shown material groups.	Material Group	Feed Factor
	M	0.8
	N	1.2
	S	0.8
	H	0.5

I.D. and Face Grooving
For I.D. and face grooving applications, reduce feed rate by 20%.

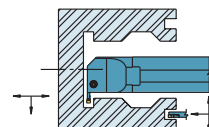

Turn and profile feed rates

Seat Size 1F

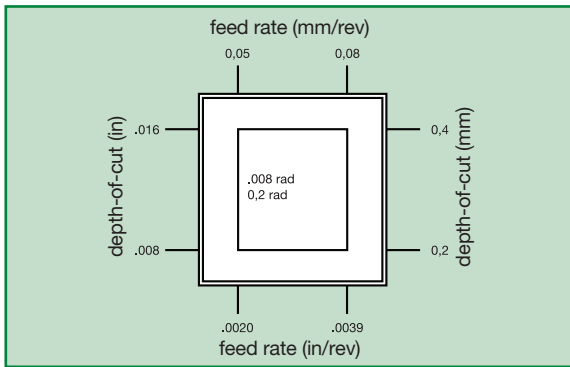

Seat Size 2

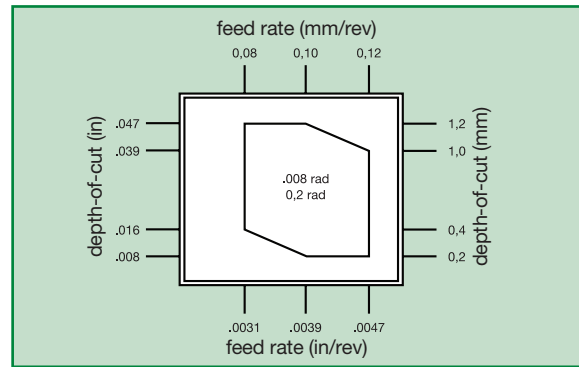

Seat Size 3

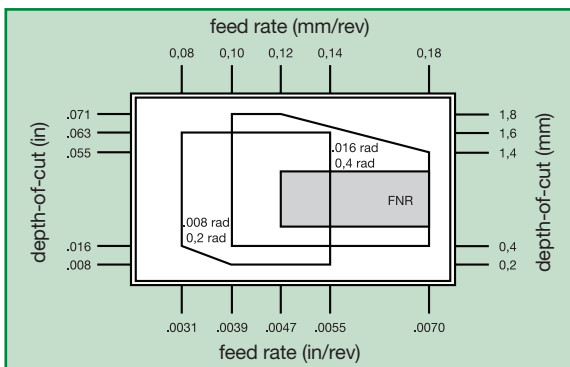

Seat Size 4

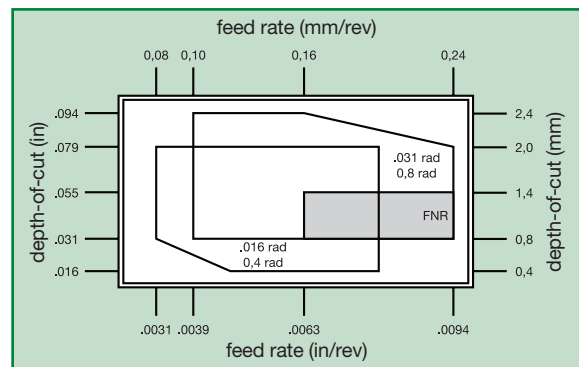

Seat Size 5

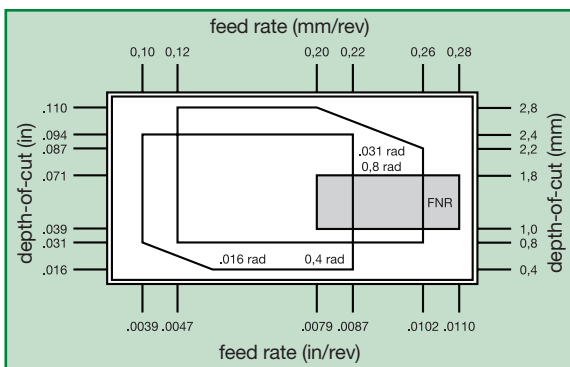

Seat Size 6

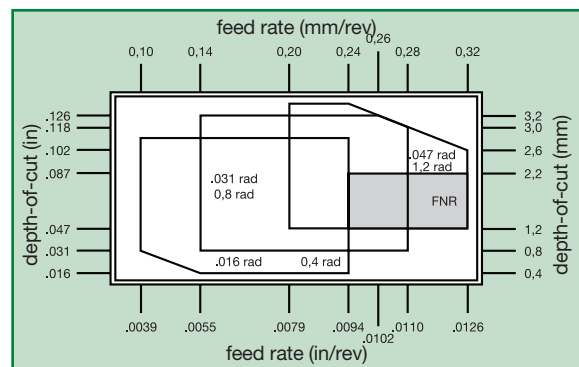

Seat Size 8

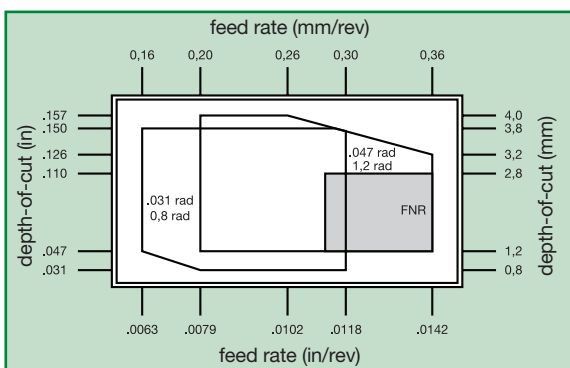

Seat Size 10

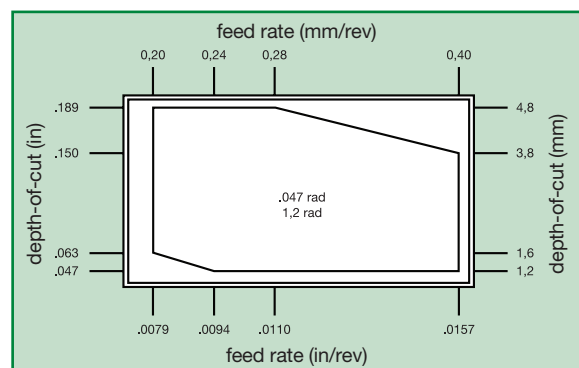

* FNR = Full Nose Radius





Recommended Starting Speeds • Metric

Material Group		WU25PT		
P	0-1	110	225	270
	2	110	160	260
	3	110	125	235
	4	60	90	160
	5	100	160	210
	6	85	120	185
M	1	90	170	245
	2	90	150	245
	3	90	140	210
K	1	100	145	225
	2	70	120	170
	3	50	85	120
N	1-2	120	440	780
	3	—	—	—
	4	100	290	490
	5	70	135	195
	6	100	170	245
S	1	8	40	60
	2	8	30	75
	3	15	40	75
	4	8	50	110

NOTE: FIRST choice starting speeds are in **bold** type.
As the average chip thickness increases, the speed should be decreased.

Grooving and Cut-Off • WGC

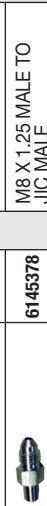
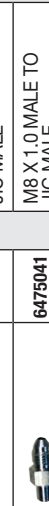
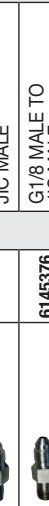
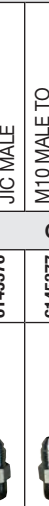
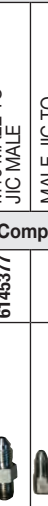
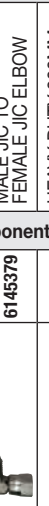
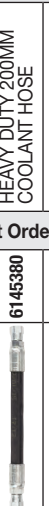
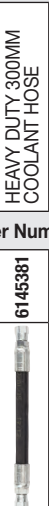
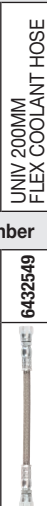
Coolant Kit

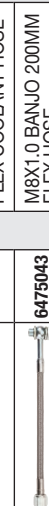
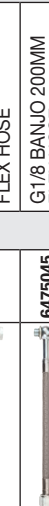
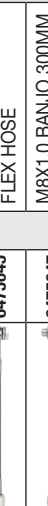
Kit Description	Order Number	Shank Size	Coolant Pressure	Component Description														
				Component Order Number														
				6145374	6145375	6145378	6475041	6145376	6145377	6145379	6145380	6145381	6432549	6432550	6475043	6475045	6475047	6475049
<i>Universal 200mm flex hose coolant kit</i>	6475019	12–40mm 1/2–1-1/2"	200 Bar 2,901 psi															
<i>Universal 300mm flex hose coolant kit</i>	6475021	12–40mm 1/2–1-1/2"	200 Bar 2,901 psi	•	•	•	•	•	•				•					
<i>M8x1.0 banjo 200mm flex hose coolant kit</i>	6475023	12–20mm 1/2–3/4"	200 Bar 2,901 psi					•	•	•					•			
<i>M8x1.0 banjo 300mm flex hose coolant kit</i>	6475025	12–20mm 1/2–3/4"	200 Bar 2,901 psi					•	•	•							•	
<i>G 1/8 banjo 200mm flex hose coolant kit</i>	6475027	25–40mm 1–1-1/2"	200 Bar 2,901 psi					•	•	•						•		
<i>G 1/8 banjo 300mm flex hose coolant kit</i>	6475029	25–40mm 1–1-1/2"	200 Bar 2,901 psi					•	•	•								•
<i>Universal 200mm heavy-duty coolant kit</i>	6145372	25–40mm 1–1-1/2"	350 Bar* 5,076 psi*	•	•			•	•	•	•							
<i>Universal 300mm heavy-duty coolant kit</i>	6145373	25–40mm 1–1-1/2"	350 Bar* 5,076 psi*	•	•			•	•	•		•						

* Max pressure for seat size 02 holders is 200 bar/2901 psi.

Individual Kit Component List



order number	catalogue number	description
6145374	1-16NPTF-JIC	Straight fitting, 1/16 NPTF male thread to JIC male thread
6145375	1-8NPTF-JIC	Straight fitting, 1/8 NPTF male thread to JIC male thread
6145378	M8X1.25-JIC	Straight fitting, M8 x 1.25 male thread to JIC male thread
6475041	M8X1-JIC	Straight fitting, M8 x 1.0 male thread to JIC male thread
6145376	G18-JIC	Straight fitting, G 1/8 male thread to JIC male thread
6145377	M10X1.5-JIC	Straight fitting, M10 x 1.5 male thread to JIC male thread
6145379	JICM-JICF-ELB	Elbow fitting, male JIC thread to female JIC thread
6145380	COOL-HOSE-200-HD	Heavy Duty 200mm Coolant hose with JIC female fitting both ends
6145381	COOL-HOSE-300-HD	Heavy Duty 300mm Coolant hose with JIC female fitting both ends
6432549	COOL-HOSE-200-FLEX	Flexible braided 200mm Coolant hose with JIC female fitting both ends
6432550	COOL-HOSE-300-FLEX	Flexible braided 300mm Coolant hose with JIC female fitting both ends
6475043	M8X1-BAN-JIC-HOSE-200	Flexible braided 200mm Coolant hose, M8 x 1.0 male thread to JIC female thread. Contains (1) M8x1.0 banjo bolt and (2) M8 bonded washers
6475045	G18-BAN-JIC-HOSE-200	Flexible braided 200mm Coolant hose, G 1/8 male thread to JIC female thread. Contains (1) G 1/8 banjo bolt and (2) G 1/8 bonded washers
6475047	M8X1-BAN-JIC-HOSE-300	Flexible braided 300mm Coolant hose, M8 x 1.0 male thread to JIC female thread. Contains (1) M8x1.0 banjo bolt and (2) M8 bonded washers
6475049	G18-BAN-JIC-HOSE-300	Flexible braided 300mm Coolant hose, G 1/8 male thread to JIC female thread. Contains (1) G 1/8 banjo bolt and (2) G 1/8 bonded washers

Individual Kit Component List



The items shown below are not part of any coolant kits shown on previous pages.

order number	catalogue number	description
6145382	M6X1-JIC	Straight fitting, M6 x 1.0 male thread to JIC male thread
6145383	JICM-JICM-STR	Straight fitting, JIC male thread to JIC male thread
6145386	G14-G18-RED	Straight fitting, G 1/4 male thread to G 1/8th male thread
6475058	R18-JIC	Straight fitting, 1/8 BSPT male thread to JIC male thread
6475059	R14-JIC	Straight fitting, 1/4 BSPT male thread to JIC male thread

Coolant Spare Parts

Included in kits; part of components.

order number	catalogue number	description
6475051	M8X1-BAN-BOLT	Banjo bolt, M8 x 1.0 male thread
6475053	G18-BAN-BOLT	Banjo bolt, G1/8 male thread
6475060	M6-BON-WASHER	M6 bonded washer
6475055	M8-BON-WASHER	M8 bonded washer
6475061	M10-BON-WASHER	M10 bonded washer
6475056	G18-BON-WASHER	G 1/8 bonded washer

Grooving and Cut-Off • WGC

Internal Coolant Delivery Guidelines

1. WGC system capable of 5076 psi (350 bar).
2. Toolholder delivered with four entry holes.
3. A quality filtration system is necessary to prevent blockages in the toolholder that will affect coolant flow and performance.
4. Machines without a proper filtering system may require modification or an inline filter.
 - For pressure >1015 psi [70 bar], use 10–20 µm filter.
 - For pressure <1015 psi [70 bar], 50–100 µm.
 - Using fine filters in low-pressure applications may affect flow rate.

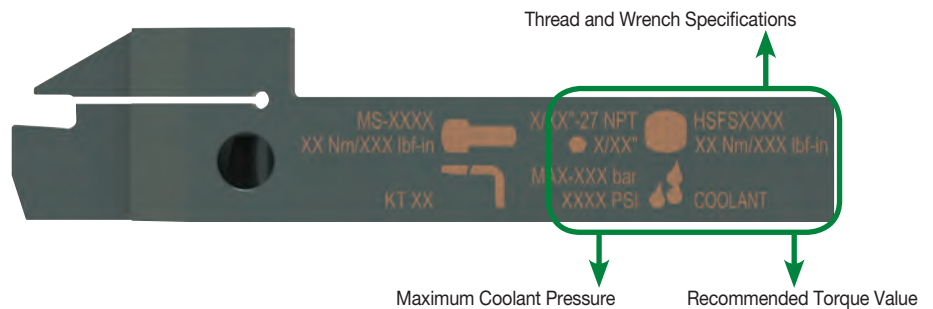
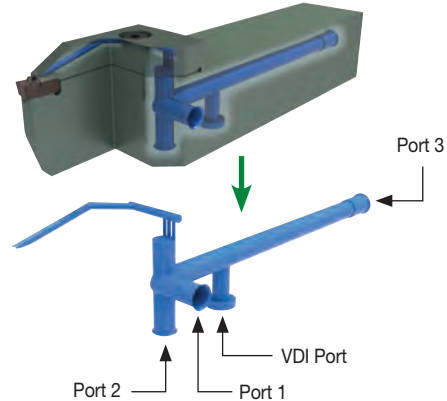

General Safety Guidelines

1. All safety doors and mechanisms must be in place before trying out the internal coolant to avoid any danger to the operator in the event of a failure.
2. Use the correct pipe fittings to connect the holders to the system. Ensure the maximum pressure recommended for the fittings are not exceeded.
3. While implementing pressure >1160 psi [80 bar], increase the pressure in steps to ensure proper functioning of insert clamping and leak-free joints.
4. While indexing inserts, ensure the pocket is free from chips and/or dirt. Also, inspect the insert and make sure there are no blockages in the coolant canal.
5. Periodically check all hoses and fittings for damage and wear for proper functioning of the system. This check should also include filters.

Internal Coolant Delivery Performance

Internal coolant offers a clear advantage in tool life and chip forming/evacuation vs. external coolant in difficult conditions and in high-pressure coolant.

Example: Chipbreaking in plunging of steel.

Flood Coolant



Material steel ST52;
Insert size 6mm; f = 0,25 mm/U

Internal Coolant



1,087 psi
(75 bar)



2,900 psi
(200 bar)

Low Pressure — If performance is at risk due to low coolant pressure, apply internal coolant in combination with external coolant to increase volume.

Recommendation to improve tool life and/or productivity: Apply high pressure coolant: 80–350 bar recommended.

VDI Assemblies

The WGC internal coolant delivery can be leveraged with VDI holding systems with both traditional or Quick-Change coolant connections.