

GROOVING

Advanced .193

Holdings .195



GROOVING Advanced

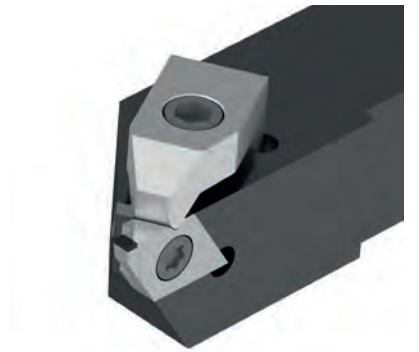

GROOVING Holders

TURNING

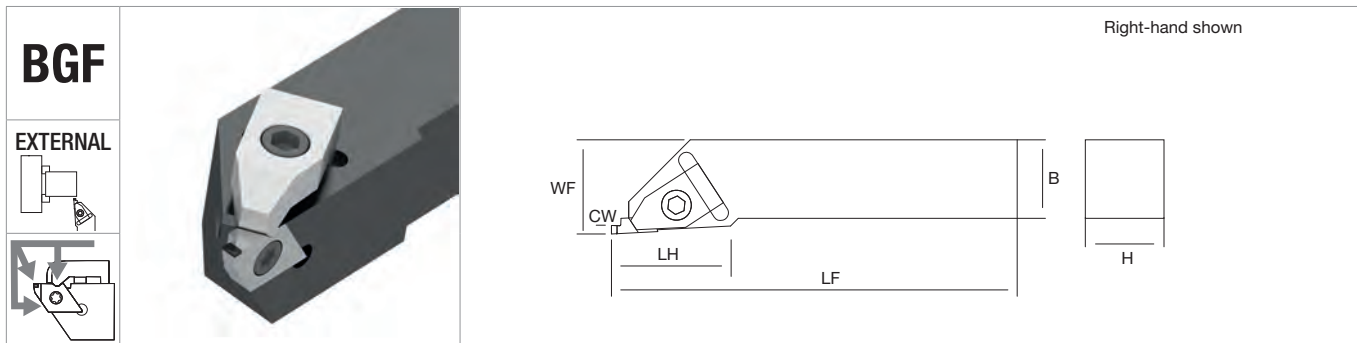

THREADING

BGF-HLD External grooving			H	B	WF	LF	LH		MID		
										R	L

CW 1 ÷ 4	BGF-HLD 1616 ^ø /L		▽		16	16	30	150	45	BGF ^ø /L□□□		
	BGF-HLD 2020 ^ø /L		●	●	20	20	30	150	45			
	BGF-HLD 2525 ^ø /L		●	●	25	25	30	150	45			

● stock standard, ▽ stock exhaustion

GROOVING



BGF-HLF 1616 ^ø /L	NT-CS300 ^ø /L	NT-SC300	NT-WR040	NT-ST300	NT-FT15
BGF-HLF 2020 ^ø /L					
BGF-HLF 2525 ^ø /L					

MILLING

DRILLING

ACCESSORIES